

**NEW!**

# BIG BENNY DRAINAGE SUMP



## SAVE TIME AND MONEY

- ★ Fast installation - replaces concrete
- ★ Tough, lightweight polyethylene
- ★ No heavy equipment needed
- ★ No gluing or grouting
- ★ Will not crack or corrode
- ★ One piece, leak-proof construction
- ★ Surface access for easy service

## IDEAL FOR

- ★ Roof and perimeter drains
- ★ Driveways and parking lots
- ★ General landscaping

**Look for the PREMIER label of quality.**

## SPECIFICATIONS

- Standard weight 65 lbs. / Max. cover 12"
- Extra heavy weight 90 lbs. / Max cover 36"
- Total vol.: 70 imp. gals.
- Slip joint pipe connections
- Pipe entry can angle up to 15° off centre
- Environmentally safe
- Do not place in direct path of vehicles
- **100 year warranty**

## \*\* SAMPLE LAYOUT

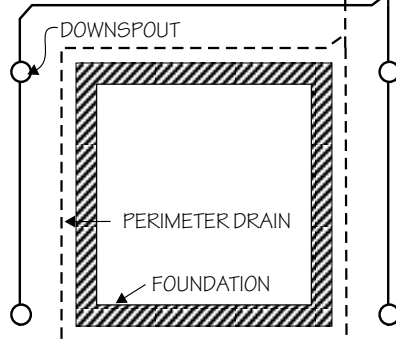

\*\* Subject to local regulations

## SECTION OF SUMP

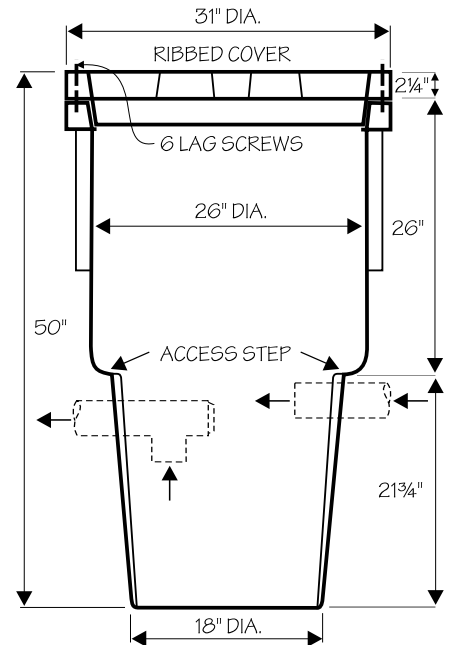

## SELECTION GUIDE

APPLICATION	MODEL #	FITTINGS
Drainage Sump	DS 70	2 - 4" inlets - invert 33" from top 1 - 4" outlet - invert 35" from top
Pump Out	PO 70	1 - 4" inlet - invert 10" from top
Catch Basin/Dry Well	CB 70	Connections and perforations as required
Cistern Tank	CIS 70	Fittings as required by customer

- Accessories - Riser 21/31



**PREMIER  
PLASTICS LTD.**

8328 River Way, Delta, BC, Canada V4G 1C4  
 Bus: (604) 952-6686 Fax: (604) 952-6696  
 Toll Free: 1-800-661-4473  
 E-mail: premier@ultranet.ca  
 www.premierplastics.com

Represented by: