

POLYETHYLENE

HORIZONTAL LEG TANKS

— Specifically designed for pick-up trucks and flat decks

WATER HAULING – PRESSURE WASHING – FERTILIZER – BRINE – DRINKING WATER – WASTE STORAGE

New low-profile design is self-supporting and increases stability when liquids are transported.

Flat surfaces on all sides of the tank provide greater flexibility in placing pipe connections.

FEATURES:

- ★ **Lightweight food-grade polyethylene**
(meets FDA Reg. 21 CFR 177.1520(c)3.1)
(CSA/NSF certification drinking water)
- ★ **Tough, long-lasting and easy to handle**
- ★ **Seamless construction – will not leak or corrode**
- ★ **UV stabilized for outside use**
- ★ **Environmentally safe**
- ★ **Fill/access cap and outlet provided** (see below)
- ★ **Colour – natural white**

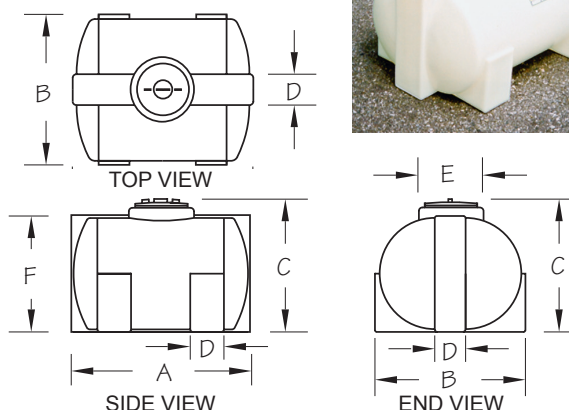

SELECTION GUIDE (U.S.A./Canada)

VOLUME			MODEL NO.		DIMENSIONS (inches)								FILL/ACCESS DIAMETER (inches)	OUTLET DIAMETER* (inches)	LOADED WEIGHT (lbs.)
U.S. Gal.	Imp. Gal.	Litres	USA	Canada	Nominal Diameter	A	B	C	D	E	F				
54	45	200	LTU54	LT45	18	39¼	25	22	6	12	18¾	8	1	500	
85	72	325	LTU85	LT72	24	39¼	30½	28¼	6	12	24½	8	1	775	
155	130	590	LTU155	LT130	30	47	40½	34	8	16¾	30¼	12	2	1,370	
210	175	795	LTU210	LT175	36	47	44	40¼	8	21¾	36	16	2	1,830	
275	230	1040	LTU275	LT230	42	47	49¾	46¼	8	21¾	42	16	2	2,400	
455	380	1725	LTU455	LT380	48	59¼	55½	51¾	8	21¾	47½	16	2	3,950	
970	810	3680	LTU970	LT810	48	100	60	50	9	23	50	16	2	8,370	

* Threaded fitting supplied loose inside tank – can be factory installed as required.
 Note: Exact measurements may vary.
 Caution: Check maximum carrying capacity of vehicle prior to use.
 Driving with a partly-filled tank may be a safety hazard.

**Look for the PREMIER label of quality.
 PREMIER PLASTICS ... Good solid tanks!**

www.premierplastics.com Toll Free: 1-800-661-4473

Represented by: